

Recycler Guide, TOMRA S2 Rugged

90377000, 90377001, 90377002, 90377050



Original

Contents

| | |
|---|----------|
| About this guide | 3 |
| Disclaimer | 4 |
| Safety instructions | 5 |
| Disassembly instruction | 7 |
| Disassemble the TOMRA S2 Rugged..... | 7 |
| Disassemble the TOMRA S2 SoftDrop..... | 10 |
| Disassemble the TOMRA S2 Storage Cabinet..... | 12 |
| Disassemble the TOMRA S2 Hood..... | 14 |

About this guide

This product contains electrical and electronic components that should be recycled by a specialist electronics recycler. Disposal and recycling of products containing electrical and electronic components may be governed by national environmental legislation.

This guide provides information pertaining to the decommissioning and recycling of TOMRA reverse vending machines and backroom equipment pursuant to the European Community directive 2012/19/EU on waste electrical and electronic equipment (WEEE).

This information shall identify the different EEE components and materials, as well as the location of dangerous substances and mixtures in EEE so that they can be properly handled. If you have any questions or feedback regarding this guide, please contact us on www.tomra.com.

Disclaimer

This Recycler Guide is intended only for information purposes. It does not guarantee the composition of any product or that the product will retain a specific composition for a specific period.

The Recycler Guide provides information on the disassembly process of a product to assign the components to the correct recycling channels. The values given are only valid in this specified context and cannot be used to create the environmental compatibility assessment of a product.

Reuse of disassembled components is not permitted. TOMRA therefore assumes no liability for errors or consequences that may result from the use of this information for anything other than assigning the product components to the correct recycling channels.

Safety instructions

Introduction

TOMRA Systems ASA is not liable for any damage caused by incorrect actions taken during the disassembly of the product/system.

The recycler is responsible for ensuring the safety of its employees performing disassembly of TOMRA products.

Safety symbols

Safety symbols are used on the safety labels on TOMRA machines. The table below lists the commonly used symbols and explains what they mean. Not all warnings will be relevant for all products.



NOTE: These symbols are designed for machine use during operation. Not all warnings may be relevant for the purpose of recycling but may be useful to understand the components that are being disassembled.

Table 1: Mandatory actions







| Symbol | Description |
|---|---|
|  | Refer to the instructions. |
|  | Use protective gloves. |
|  | Use ear protection. |
|  | Use eye protection. |
|  | Switch off power before carrying out maintenance or repair. |
|  | Disconnect the mains power cable before carrying out maintenance or repair. |

Table 2: Prohibited actions









| Symbol | Description |
|---|---|
|  | Do not reach in. |
|  | Do not clean with a hose or spray with water. |
|  | Do not step on this surface. |

Table 3: Warnings

| Symbol | Description |
|---|--|
|  | General warning sign. Indicates a warning, caution or presence of a hazard, specified by text or symbol. |
|  | Electricity hazard: <ul style="list-style-type: none"> • Disconnect power before opening or handling • High voltage present • No serviceable parts inside |
|  | The system can start without warning. |
|  | Drawing in and crush hazard. Keep hands and clothes clear. |
|  | Indicates an overhead obstacle. |
|  | Tip-over hazard. The machine is top-heavy and may tip over when transported. |

Disassembly instruction

Disassemble the TOMRA S2 Rugged

Part ID

TOMRA S2 Rugged (90377000)

Recommended tools

- Socket wrenches 10, 13, 17 and 24 mm
- Torx screwdrivers T20, T25 and T30
- Hex key 4 mm
- Crosshead screwdrivers PZ1 and PZ2
- Side-cutting pliers
- Pallet truck

Disassemble all parts and sort the components per material types listed below. Do not mix material types.



Main parts

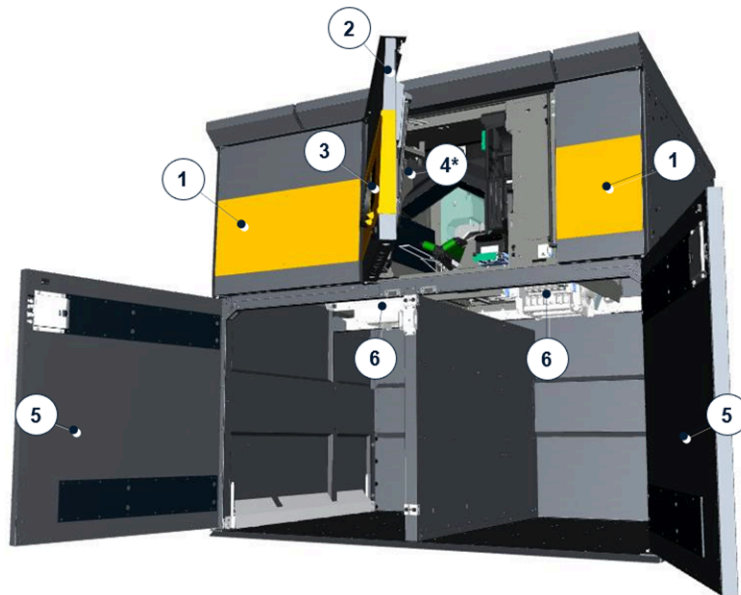

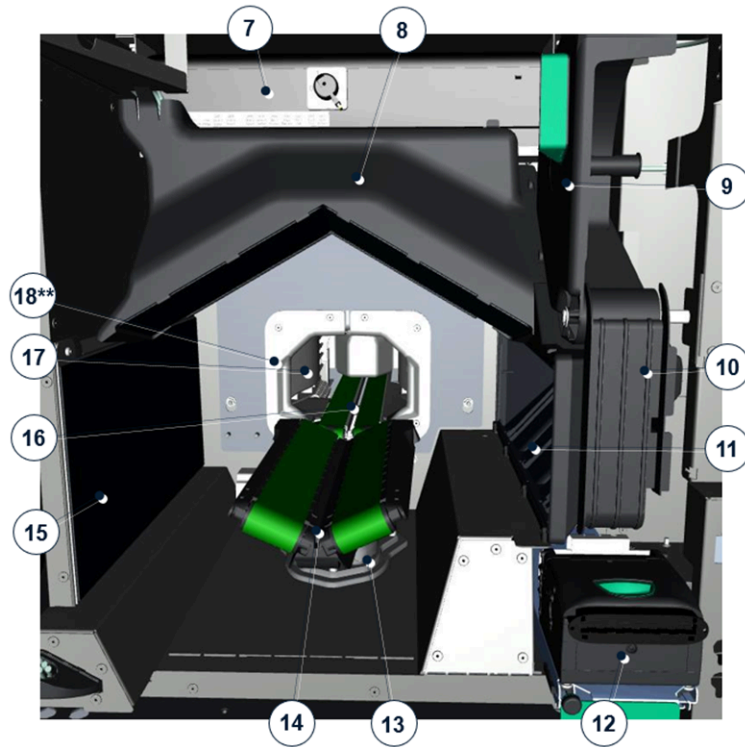

- 1. Side cover
- 2. Main door
- 3. MMI unit
- 4. OneRing *
- 5. Lower doors
- 6. Compactor/glass crusher
- 7. Power box
- 8. Arch reflector
- 9. Paper holder
- 10. Paper guide
- 11. Camera unit
- 12. Printer
- 13. Infeed docking-station
- 14. Infeed conveyor
- 15. Shape reflector
- 16. Sorter conveyor
- 17. Sorter
- 18. Side conveyor (if present, located behind wall) **

Material types







NOTE: There are variants of this machine, minor weight differences may occur.

| Material | Weight (kg) |
|--|--------------------|
| Steel and iron | 510.8 |
| Aluminium | 2.8 |
| Electrical, electronic and electromechanical (EEE) parts | 14.6 |
| Plastic | 8.8 |

| Material | Weight (kg) |
|----------|-------------|
| Rubber | 0.2 |
| Glass | 3.6 |

Recommended disassembly procedure

| Step | Materials |
|--|--|
| 1 Remove main parts (1-5) | Steel, EEE parts (cables, circuit boards), plastic, rubber  NOTE: Circuit boards shall be destroyed/ grinded |
| 2 Remove main parts (7-15) | Steel, aluminum, EEE parts (cables, circuit boards, motor), plastic, rubber  NOTE: Circuit boards shall be destroyed/ grinded |
| 3 Remove the conveyors, the sorter and the compactor and/or glass crusher (6, 16-18) | Steel, EEE parts (cables, circuit boards, motor), plastic, rubber  NOTE: Circuit boards shall be destroyed/ grinded |
| 4 Remove the cables. | EEE parts |
| 5 Disassemble the framework | Steel, plastic, rubber |
| 6 Disassemble the assembled units (1-18) | Steel, aluminium, EEE parts (cables, circuit boards, motor), plastic, glass, rubber  NOTE: Circuit boards shall be destroyed/ grinded |

** The weight of the side conveyor is integrated into S2 as part of the softdrop solution, and therefore is not included in the total material weight calculation for S2. Refer to the softdrop cabinet specifications.

* The OneRing reader has a glass cover that shall be removed and recycled

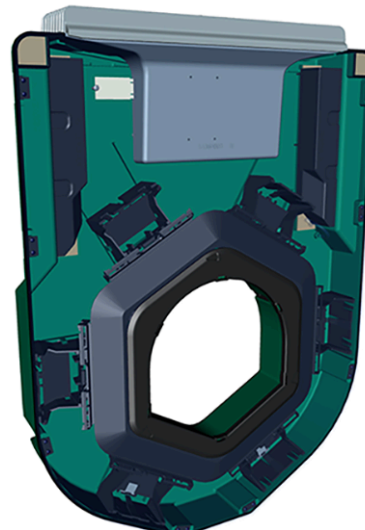

Disassemble the TOMRA S2 SoftDrop

Part ID

TOMRA S2 SoftDrop Cabinet (90377001)

Recommended tools

- Socket wrenches 10, 13, 17 and 24 mm
- Torx screwdrivers T20, T25 and T30
- Hex key 4 mm
- Crosshead screwdrivers PZ1 and PZ2
- Side-cutting pliers
- Pallet truck

Disassemble all parts and sort the components per material types listed below. Do not mix material types.



Main parts

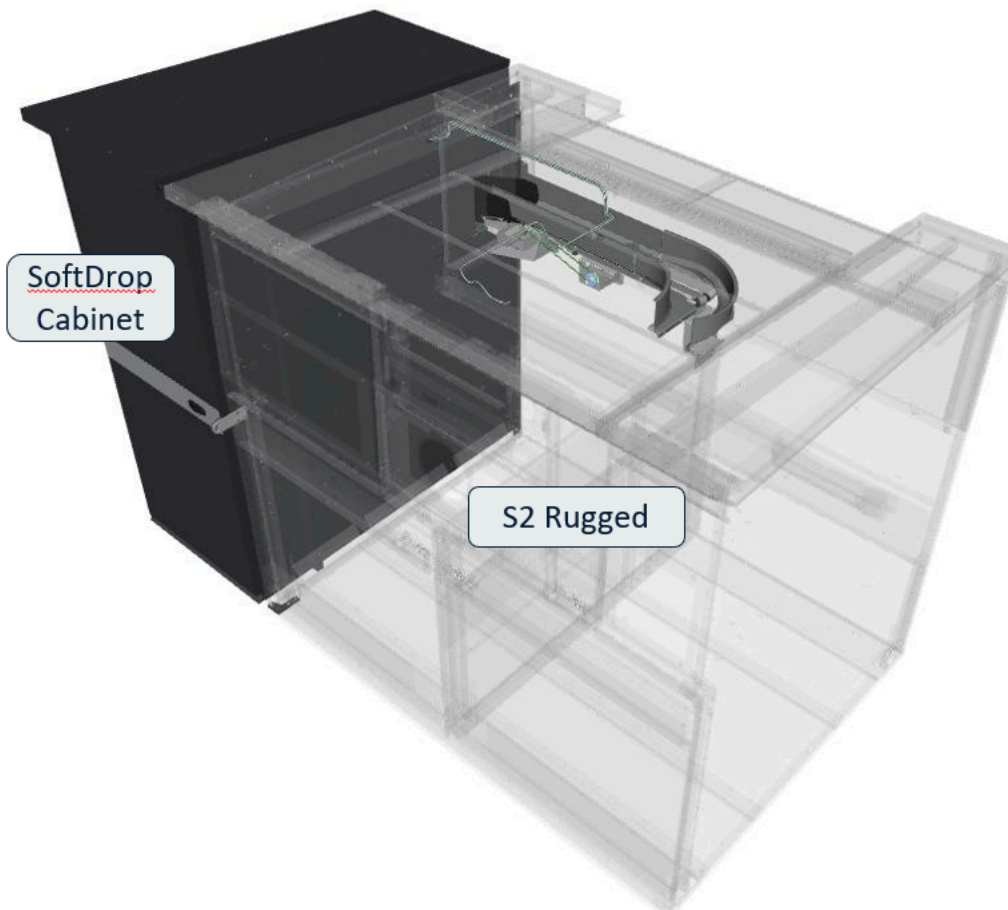

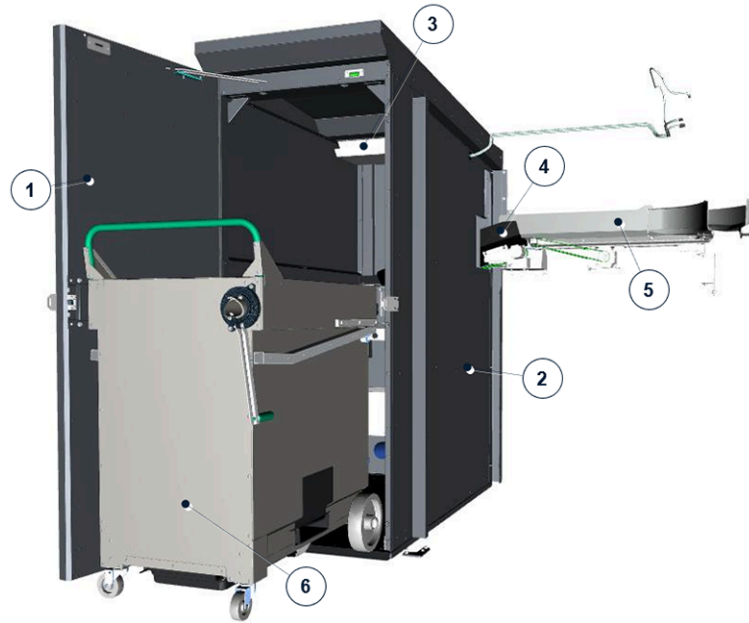

- 1. Door
- 2. Cabinet
- 3. Electronics and cables
- 4. SoftDrop conveyor
- 5. Turn conveyor
- 6. SoftDrop bin

Material types

| Material | Weight (kg) |
|--|--------------------|
| Steel and iron | 222.8 |
| Aluminium | 0.3 |
| Electrical, electronic and electromechanical (EEE) parts | 10.95 |
| Plastic | 3.5 |
| Rubber | 1 |

Recommended disassembly procedure

- | Step |
|---|
| 1 Remove door and disassemble the door (1) |
| 2 Remove electronics and cables (3) |
| 3 Remove and disassemble the conveyors (4-5) |
| 4 Disassemble the framework (2) |
| 5 Disassemble the SoftDrop bin (6) |

- | Materials |
|---|
| Steel, aluminum, plastic |
| Steel, EEE parts (cables, circuit boards), plastic |
|  NOTE: Circuit boards shall be destroyed/ grinded |
| Steel, EEE parts (cables, motor), plastic, rubber |
| Steel, aluminum, EEE parts (cables, motor), plastic, rubber |
| Steel, aluminium, EEE parts (cables, motor), plastic, rubber |

Disassemble the TOMRA S2 Storage Cabinet

Part ID

TOMRA S2 Storage Cabinet (90377002)

Recommended tools

- Socket wrenches 10, 13 and 17 mm
- Torx screwdrivers T20, T25 and T30
- Hex key 4 mm
- Crosshead screwdrivers PZ1 and PZ2
- Side-cutting pliers
- Pallet truck

Disassemble all parts and sort the components per material types listed below. Do not mix material types.



Main parts



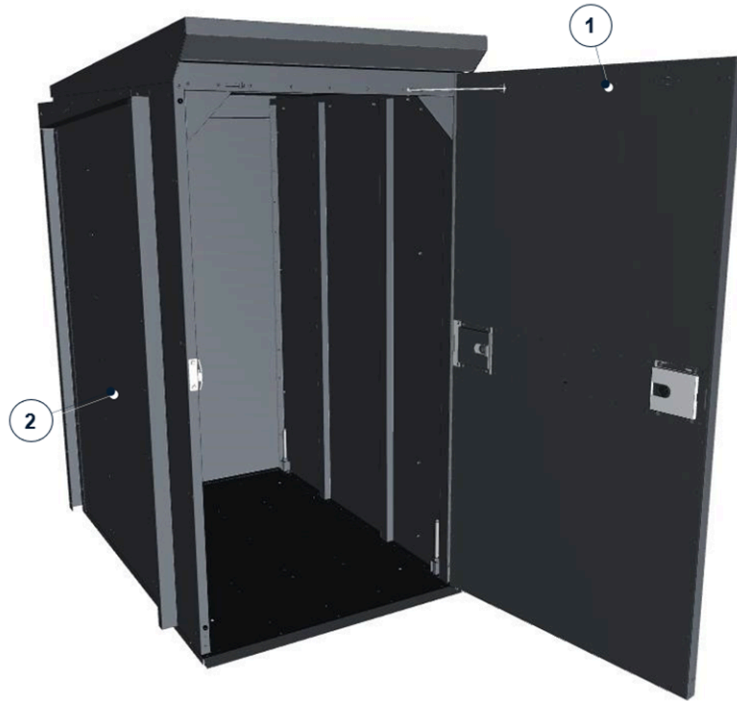

- 1. Door
- 2. Cabinet

Material types

| Material | Weight (kg) |
|-----------------|--------------------|
| Steel and iron | 165 |
| Aluminium | 0.1 |
| Plastic | 0.1 |
| Rubber | 0.1 |

Recommended disassembly procedure

| Step | Materials |
|--|----------------------------------|
| 1 Remove the door and disassemble the door (1) | Steel, aluminum, plastic, rubber |
| 2 Disassemble the framework (2) | Steel, plastic, rubber |

Disassemble the TOMRA S2 Hood

Part ID

TOMRA S2 Hood (90377050)

Recommended tools

- Socket wrenches 10 mm

Disassemble all parts and sort the components per material types listed below. Do not mix material types.



Main parts

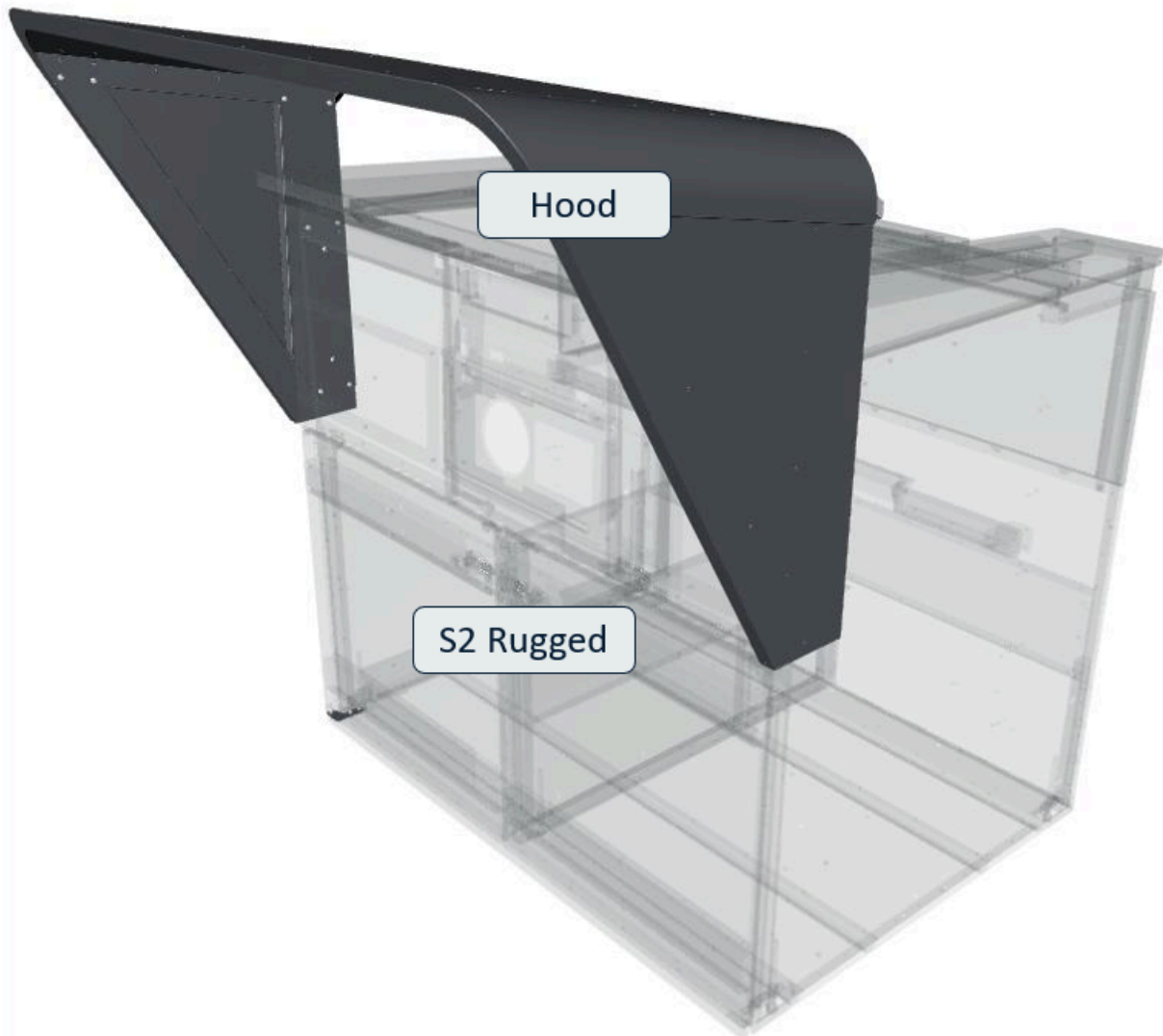



1. Hood

Material types

Material

Steel

Weight (kg)

65

Recommended disassembly procedure

Step

1 Remove and disassemble the Hood (1)

Materials

Steel



TOMRA Systems ASA
Drengsrudhagen 2
NO-1385 Asker
NORWAY

www.tomra.com